

Photointerrupters(Reflective)

SG - 105

The SG - 105 reflective sensor combines a GaAs IRED with a high - sensitivity phototransistor in a super - mini package, reducing installation space.

FEATURES

- Compact
- High performance
- High - speed response
- Easy to mount on P.C.B.
- Widely applicable

APPLICATIONS

- Timing sensors
- Edge sensors
- Micro floppy disk drives
- Level sensors of liquid

DIMENSIONS

(Unit : mm)

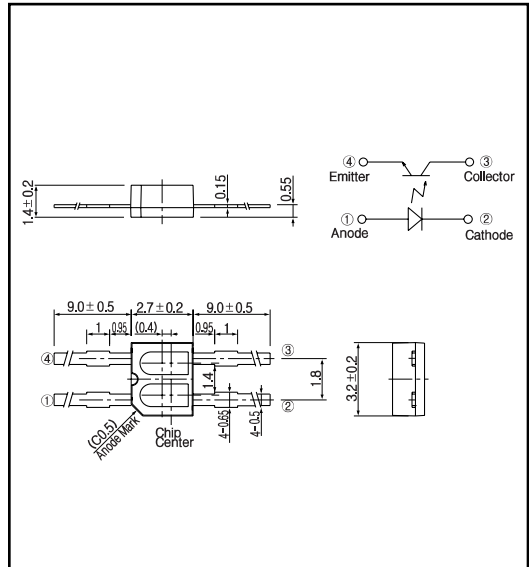

MAXIMUM RATINGS

(Ta=25)

	Item	Symbol	Rating	Unit
Input	Power dissipation	P_D	75	mW
	Reverse voltage	V_R	5	V
	Forward current	I_F	50	mA
	Pulse forward current ^{*1}	I_{FP}	1	A
Output	Collector power dissipation	P_C	50	mW
	Collector current	I_C	20	mA
	C - E voltage	V_{CE0}	30	V
	E - C voltage	V_{ECO}	3	V
	Operating temp.	$T_{opr.}$	- 20 ~ +85	
	Storage temp.	$T_{stg.}$	- 30 ~ +100	
	Soldering temp. ^{*2}	$T_{sol.}$	240	

*1. t w 100 μ sec.period : T=10msec.

*2. For MAX. 5 seconds at the position of 2mm from the package

ELECTRO-OPTICAL CHARACTERISTICS

(Ta=25)

	Item	Symbol	Conditions	Min.	Typ.	Max.	Unit.
Input	Forward voltage	V_F	$I_F=10mA$			1.3	V
	Reverse current	I_R	$V_R=5V$			10	μA
	Peak wavelength	λ_p			940		nm
Output	Collector dark current	I_{CEO}	$V_{CE}=10V$			0.2	μA
Light current		I_L	$V_{CE}=5V, I_F=10mA$	90			μA
Leakage current		I_{CEO0}	$V_{CE}=5V, I_F=10mA$			0.2	μA
Switching speeds	Rise time	t_r	$V_{CC}=2V, I_F=100\mu A$		30		μ sec.
	Fall time	t_f	$R_L=1K$		25		μ sec.

Collector power dissipation Vs. Ambient temperature

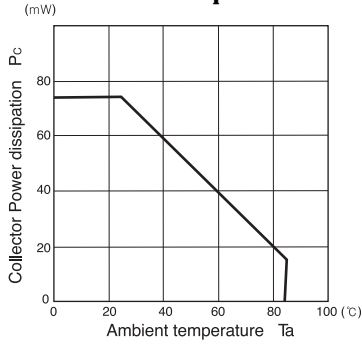

Forward current Vs. Forward voltage

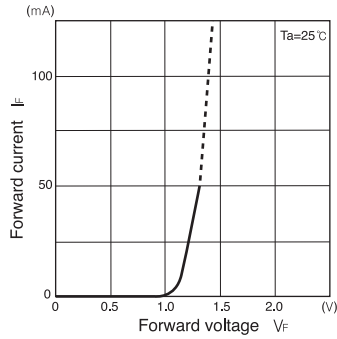

Light current Vs. Forward current

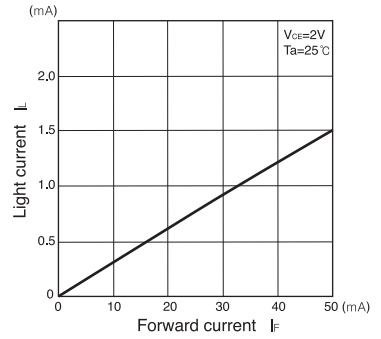

Light current Vs. Collector-Emitter voltage

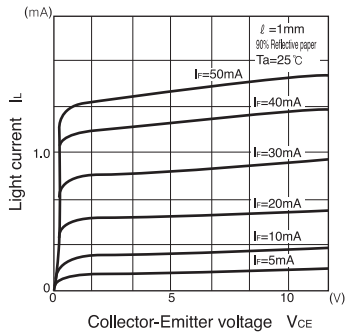

Relative light current Vs. Ambient temperature

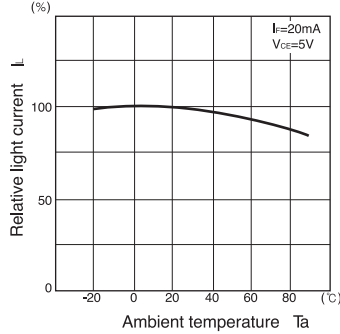

Dark current Vs. Ambient temperature

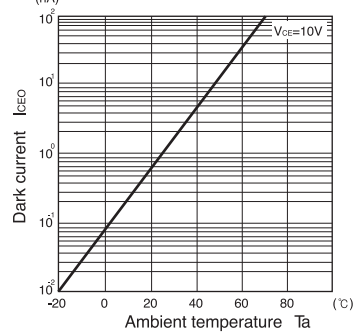

Switching time Vs. Load resistance

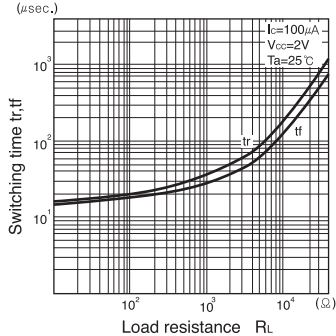

Relative light current Vs. Moving distance

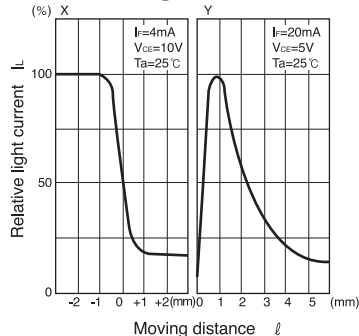

Switching time measurement circuit

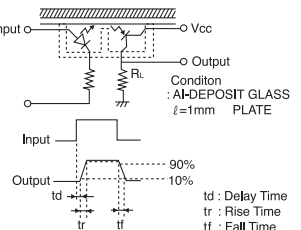

Method of measuring position characteristic

