

SCHEMATIC

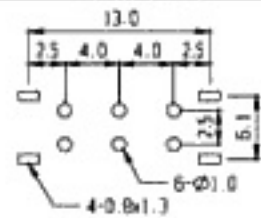

PCB LAYOUT

RoHS Compliance

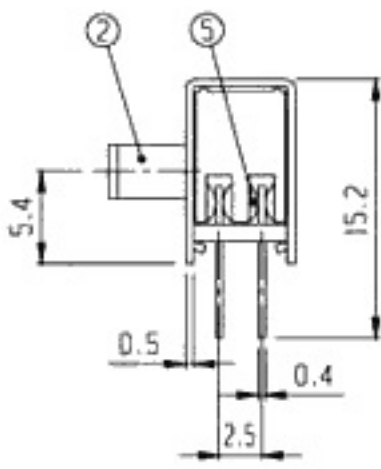
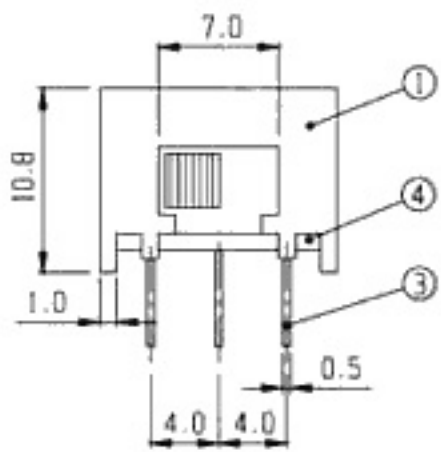

7	BALL	STEEL	1						
5	CONTACT	P B S	2	Ag PLATED	6	SPRING	STEEL WIRE	1	
3	TERMINAL	BRASS	6	Ag PLATED	4	TERMINAL BASE	PHENOL RESIN	1 NATURAL	
1	FRAME	S P C C	1	Ni PLATED	2	KNOB	P O M	1 EG 3-12	
NO	PART	MATERIAL	QTY	REMARKS	NO	PART	MATERIAL	QTY	REMARKS

ISSUED

SPECIFICATION

TITLE: SIDE KNOB SLIDE SWITCH (2P2T)



RATING: DC 30V 0.3A  
 CONTACT RESISTANCE: 30mΩ max.  
 INSULATION RESISTANCE: 500MΩ at 500V DC  
 WITHSTAND VOLTAGE: AC 500V for 1 minute  
 OPERATION FORCE: REFER ATTACH SPECIFICATION  
 SWITCHING LIFE: 10K cycles min.

MODEL NO: SK-22H07 ( EG )

TOLERANCE	UNIT: MM	DWN.	<i>hoo</i>
UP TO 1.0:±0.1	SCALE: 2.5:1	CHK'D.	<i>hoo</i>
1.0 TO 10.0:±0.2	VERSION: 01	APPD.	<i>hoo</i>
OVER 10.0:±0.3	DRWG NO:		