

RoHS
Compliance

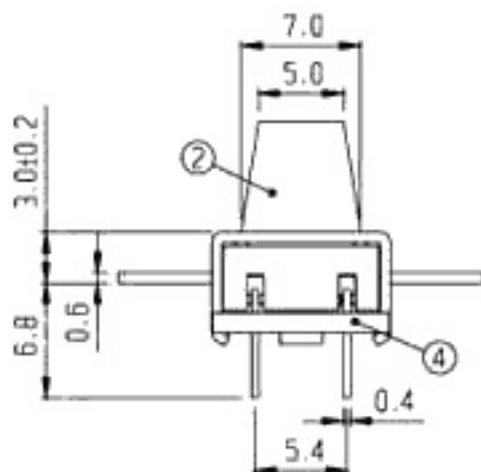
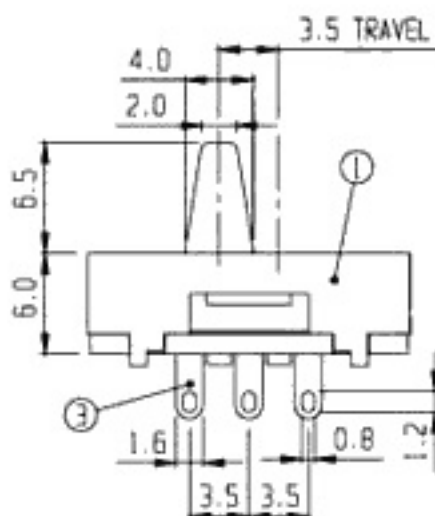

7	BALL	STEEL	1						
5	CONTACT	P B S	2	Ag PLATED	6	SPRING	STEEL WIRE	1	
3	TERMINAL	BRASS	6	Ag PLATED	4	TERMINAL BASE	PHENOL RESIN	1	
1	FRAME	S P C C	1	BLACK PLATED	2	KNOB	A B S	1	
NO	PART	MATERIAL	QTY	REMARKS	NO	PART	MATERIAL	QTY	REMARKS

ISSUED

SPECIFICATION

TITLE: SLIDE SWITCH (2P2T)

RATING: DC 30V 0.3A
 CONTACT RESISTANCE: 30mΩ max.
 INSULATION RESISTANCE: 500MΩ at 500V DC
 WITHSTAND VOLTAGE: AC 500V for 1 minute
 OPERATION FORCE: REFER ATTACH SPECIFICATION
 SWITCHING LIFE: 10X cycles min.

MODEL NO: SS-22G01

TOLERANCE UNIT: MM
 UP TO 1.0:±0.1 SCALE:2.5:1
 1.0 TO 10.0:±0.2 VERSION: 01
 OVER 10.0:±0.3 DRWG NO:

DWN. *hoo*
 CHK'D. *hoo*
 APPD. *[Signature]*

