

SALFS FORMAT

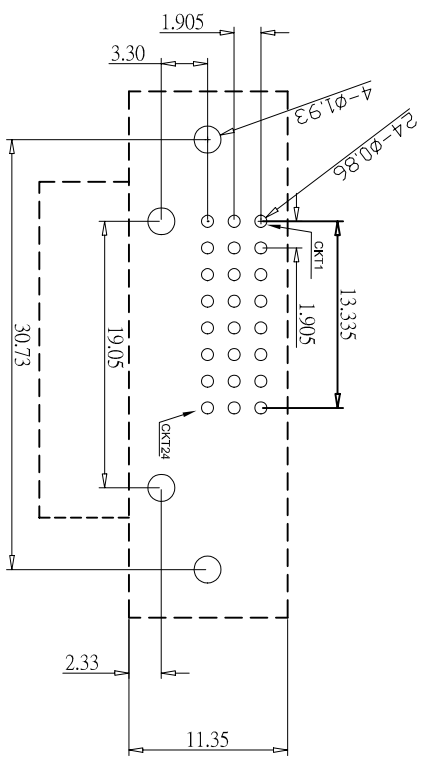
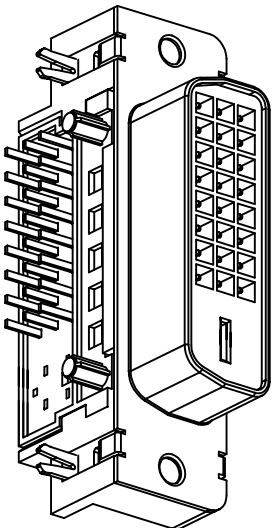
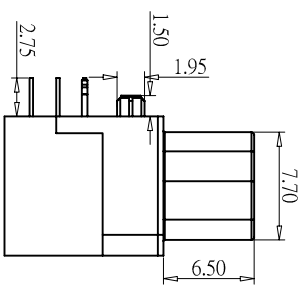
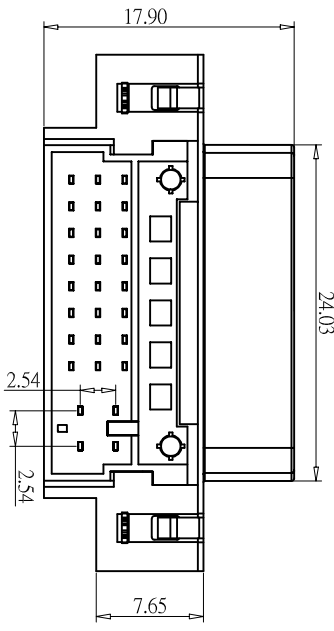
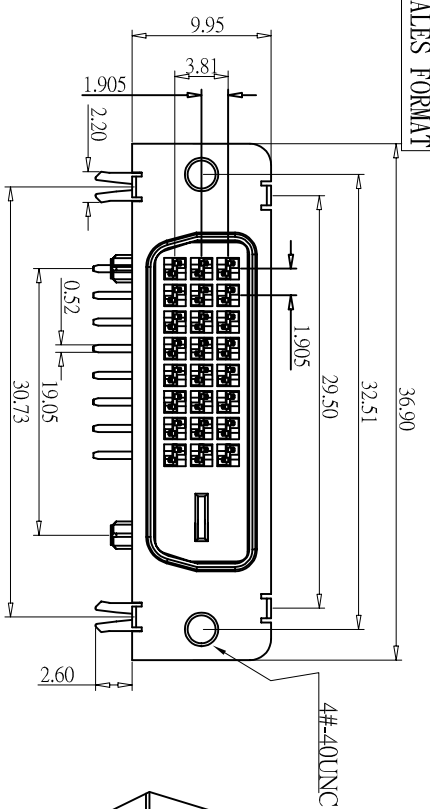

P.C.B LAYOUT

ROHS

| REV | DESCRIPTION | MODIFICATION | DATE |
|-----|-------------|--------------|----------|
| A/0 | 新制定 | | 05.08.04 |
| A/1 | 變更一 | 料號編碼變更 | 06.05.12 |

*MATERIAL

BODY : PB130% UL 94V-0 RATED, COLOR: WHITE
 LATCH : PA66+30% G.F 94V-0 RATED, COLOR: WHITE
 CONTACTS : BRASS
 CONTACT PLATING : GOLD PLATING OVER NICKEL ON CONTACT AREA
 TIN PLATING ON TERMINAL

*MECHANICAL

MATING FORCE : 4.5 KG MAX. @ 25 MM/MINUTE
 UNMATING FORCE : 1.0 KG MIN. AND 4.0 KG MAX. @ 25 MM/MINUTE
 DURABILITY : 100 MATING CYCLES

*ELECTRICAL SPECIFICATION

INSULATION RESISTANCE : 1000 MEGOHMS MIN
 DIELECTRIC WITHSTANDING VOLTAGE : 500 V DC RMS ± 50 V 60 HZ
 CURRENT RATING : 1.5 AMPERES MIN
 SHELL RESISTANCE : 50 MIILOHMS MAX./INITIAL; 50 MIILOHMS
 MAX.CHANGE FROM INITIAL
 CONTACT RESISTANCE : 20 MIILOHMS MAX.

*ENVIRONMENTAL
 OPERATING TEMPERATURE : -20* TO 85*

*HOW TO ORDER

PART NUMBER :

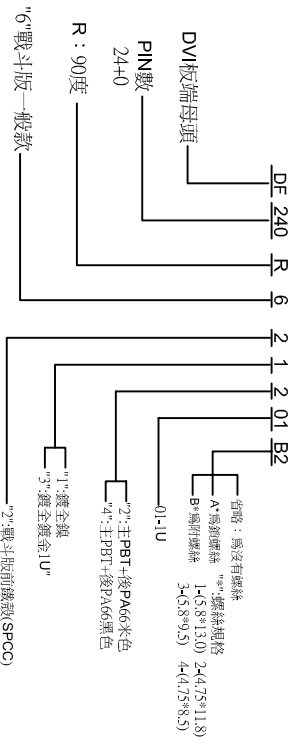
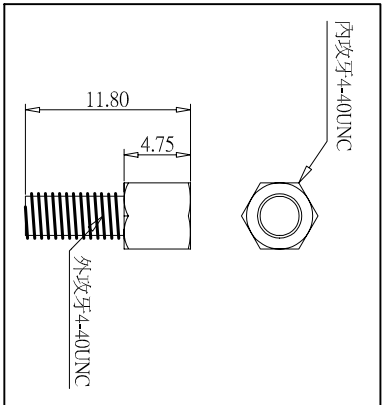

| | | | | | | | | | |
|------------|--|----------|--|---------------------------|--|-------------|--|----------|--|
| 未標示公差尺寸值 | | TITLE: | | DVI(24+0)6F90度附4.75*11.80 | | DRAWN BY | | 聶玉忠 | |
| METRIC | | PART NO: | | DF240R6-21201B2 | | DESIGNED BY | | | |
| .0=±0.35 | | FILE NO: | | ZK-3-D-001 | | APPROVAL BY | | | |
| .00=±0.25 | | SCALE | | 1:1 | | DRAW NO | | COSI-413 | |
| .000=±0.15 | | REV | | A/1 | | UNIT | | mm | |